

0.200" 4-Character 5 x 7 Dot Matrix Alphanumeric Intelligent Display® Devices with Memory/Decoder/Driver

Lead (Pb) Free Product - RoHS Compliant

DLR2416, DLO2416, DLG2416

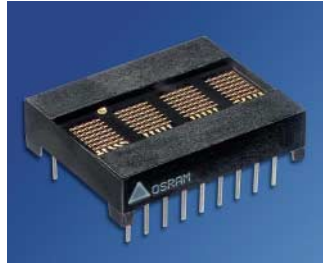

Description

The DLR/DLO/DLG2416 is a four digit 5 x 7 dot matrix display module with a built-in CMOS integrated circuit. This display is X/Y stackable.

The integrated circuit contains memory, ASCII ROM decoder, multiplexing circuitry and drivers. Data entry is asynchronous and can be random. A display system can be built using any number of DLX2416s since each digit can be addressed independently and will continue to display the character last stored until replaced by another.

System interconnection is very straightforward. The least significant two address bits (A0, A1) are normally connected to the like-named inputs of all displays in the system. With two chip enables ($\overline{CE1}$ and $\overline{CE2}$) four displays (16 characters) can easily be interconnected without a decoder.

Data lines are connected to all DLX2416s directly and in parallel, as is the write line (\overline{WR}). The display will then behave as a write-only memory.

The cursor function causes all dots of a digit position to illuminate at half brightness. The cursor is not a character, and when removed the previously displayed character will reappear.

The DLX2416 has several features superior to competitive devices. True "blinking" allows the designer to dim the display for more flexibility of display presentation. Finally the CLR clear function will clear the cursor RAM and the ASCII character RAM simultaneously.

The character set consists of 128 special ASCII characters for English, German, Italian, Swedish, Danish, and Norwegian.

All products are subjected to out-going AQLs of 0.25% for brightness matching, visual alignment and dimensions, 0.065% for electrical and functional.

Features

- 0.200" High, Dot Matrix Character
- 128 Special ASCII Characters for English, German, Italian, Swedish, Danish, and Norwegian Languages
- Wide Viewing Angle: X Axis $\pm 50^\circ$ Maximum, Y Axis $\pm 75^\circ$ Maximum
- Close Multi-line Spacing, 0.8" Centers
- Fast Access Time, 110 ns at 25°C
- Full Size Display for Stationary Equipment
- Built-in Memory
- Built-in Character Generator
- Built-in Multiplex and LED Drive Circuitry
- Direct Access to Each Digit Independently and Asynchronously
- Independent Cursor Function
- Memory Function: Clears Character and Cursor Memory Simultaneously
- True Blanking for Intensity Dimming Applications
- End Stackable, 4-Character Package
- Intensity Coded for Display Uniformity
- Extended Operating Temperature Range: -40°C to $+85^\circ\text{C}$
- Superior ESD Immunity
- Wave Solderable
- TTL Compatible over Operating Temperature Range
- Interdigit Blanking

See Appnotes 18, 19, 22, and 23 for additional information.

Ordering Information

Type	Color of Emission	Ordering Code
DLR2416	red	Q68000A8094
DLO2416	high efficiency red	Q68000A8095
DLG2416	green	Q68000A8096

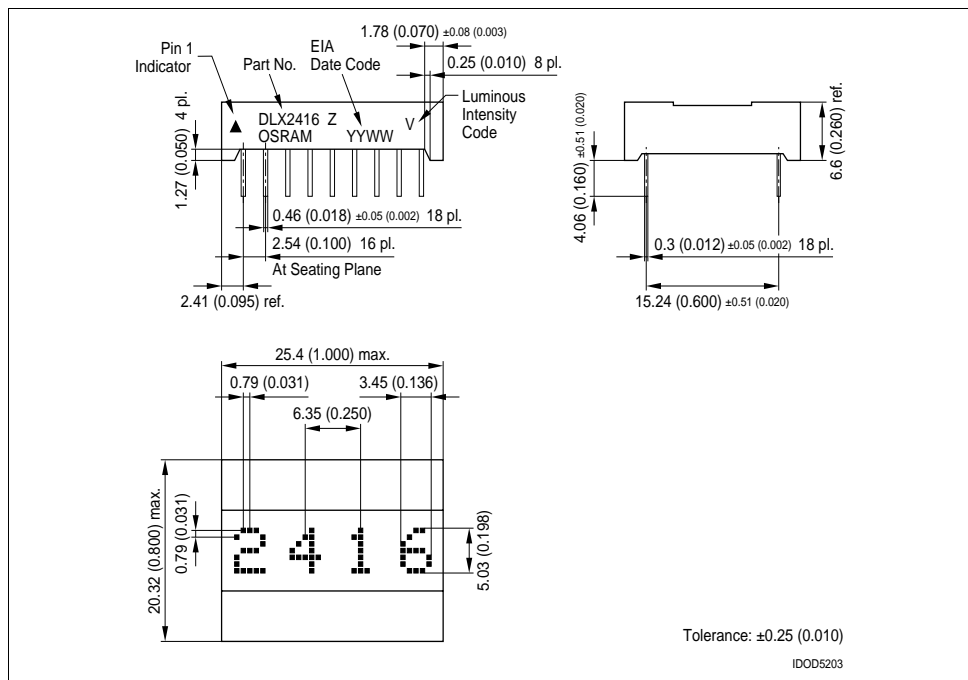

Maximum Ratings

Parameter	Symbol	Value	Unit
Operating temperature range	T_{op}	- 40 ... + 85	°C
Storage temperature range	T_{stg}	- 40 ... + 100	°C
DC supply voltage		- 0.5 ... + 7.0	V
Input Voltage, Respect to GND (all inputs)		- 0.5 to $V_{CC} + 0.5$	V
Solder temperature 0.063" (1.59 mm) below seating plane, $t < 5.0$ s	T_s	260	°C
Relative humidity at 85°C	RH	85	%

Characteristics $(T_A = 25\text{ °C})$

Parameter	Symbol	Values			Unit
		DLR2416	DLO2416	DLG2416	
		red	high efficiency red	green	
Wavelength at peak emission (typ.) $I_F = 0$ mA	λ_{peak}	660	630	565	nm
Viewing angle (off normal axis), hor. (typ.) ver. (typ.)	2φ	± 50 ± 75	± 50 ± 75	± 50 ± 75	deg deg.
Character Height	h	0.200 5.08	0.200 5.08	0.200 5.08	inch mm
Time averaged luminous intensity (100% brightness, $V_{CC} = 5.0$ V) (typ.)		60	100	120	$\mu\text{cd}/\text{LED}$
LED to LED intensity matching (max.)		1.8:1.0	1.8:1.0	1.8:1.0	
LED to LED hue matching at $V_{CC} = 5.0$ V (max.)				± 2.0	nm

Top View

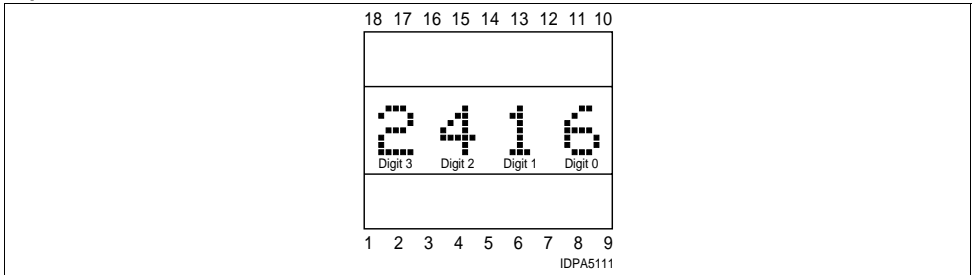

Pins and Functions

Pin	Function	Pin	Function	Pin	Function
1	$\overline{CE1}$ Chip Enable	7	A1 Digit Select	13	D2 Data Input
2	$\overline{CE2}$ Chip Enable	8	A0 Digit Select	14	D3 Data Input
3	\overline{CLR} Clear	9	V_{CC}	15	D6 Data Input
4	CUE Cursor Enable	10	GND	16	D5 Data Input
5	\overline{CU} Cursor Select	11	D0 Data Input	17	D4 Data Input
6	\overline{WR} Write	12	D1 Data Input	18	\overline{BL} Display Blank

Timing Characteristics - Write Cycle Waveforms

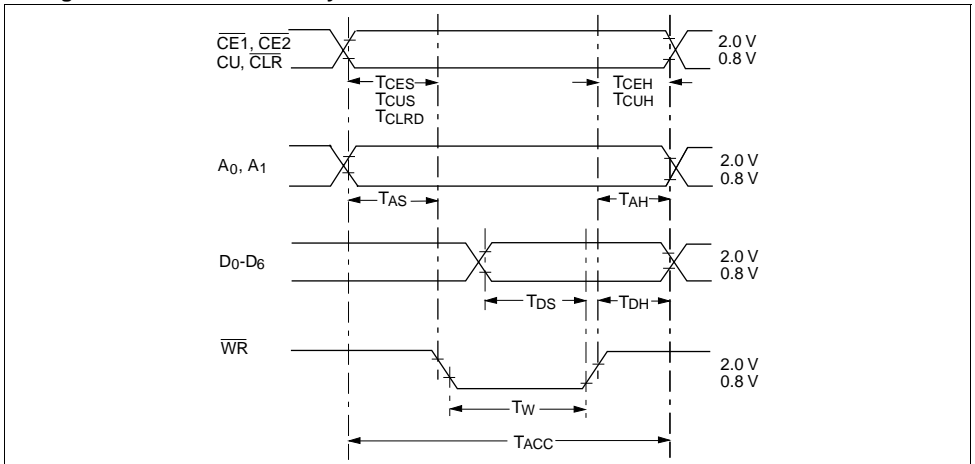

Note: These waveforms are not edge triggered.

DC Characteristics

Parameter	-40°C			+25°C			+85°C			Unit	Condition
	Min.	Typ.	Max.	Min.	Typ.	Max.	Min.	Typ.	Max.		
I_{CC} 80 Dots on	—	135	160	—	110	130	—	95	115	mA	$V_{CC}=5.0\text{ V}$
I_{CC} Cursor all Dots at 50%	—	—	135	—	—	100	—	—	100	mA	$V_{CC}=5.0\text{ V}$
I_{CC} Blank	—	2.8	4.0	—	2.3	3.0	—	2.0	2.5	mA	$V_{CC}=5.0\text{ V}$ $BL=0.8\text{ V}$
I_{IL} (all inputs)	30	60	120	25	50	100	20	40	80	μA	$V_{IN}=0.8\text{ V}$, $V_{CC}=5.0\text{ V}$
V_{IH}	2.0	—	—	2.0	—	—	2.0	—	—	V	$V_{CC}=5.0\text{ V}$ $\pm 0.5\text{ V}$
V_{IL}	—	—	0.8	—	—	0.8	—	—	0.8	V	$V_{CC}=5.0\text{ V}$ $\pm 0.5\text{ V}$
V_{CC}	4.5	5.0	5.5	4.5	5.0	5.5	4.5	5.0	5.5	V	—

AC Characteristics (guaranteed minimum timing parameters at $V_{CC}=5.0\text{ V} \pm 0.5\text{ V}$)

Parameter	Symbol	-40°C	+25°C	+85°C	Unit
Chip Enable Set Up Time	T_{CES}	0	0	0	ns
Address Set Up Time	T_{AS}	10	10	10	ns
Cursor Set Up Time	T_{CUS}	10	10	10	ns
Chip Enable Hold Time	T_{CEH}	0	0	0	ns
Address Hold Time	T_{AH}	20	30	40	ns
Cursor Hold Time	T_{CUH}	20	30	40	ns
Clear Disable Time	$T_{CLR D}$	1.0	1.0	1.0	μs
Write Time	T_W	60	70	90	ns
Data Set Up Time	T_{DS}	20	30	50	ns
Data Hold Time	T_{DH}	20	30	40	ns
Clear Time	T_{CLR}	1.0	1.0	1.0	μs
Access Time	T_{ACC}	90	110	140	ns

Note: $T_{ACC} = \text{Set Up Time} + \text{Write Time} + \text{Hold Time}$.

Internal Block Diagram

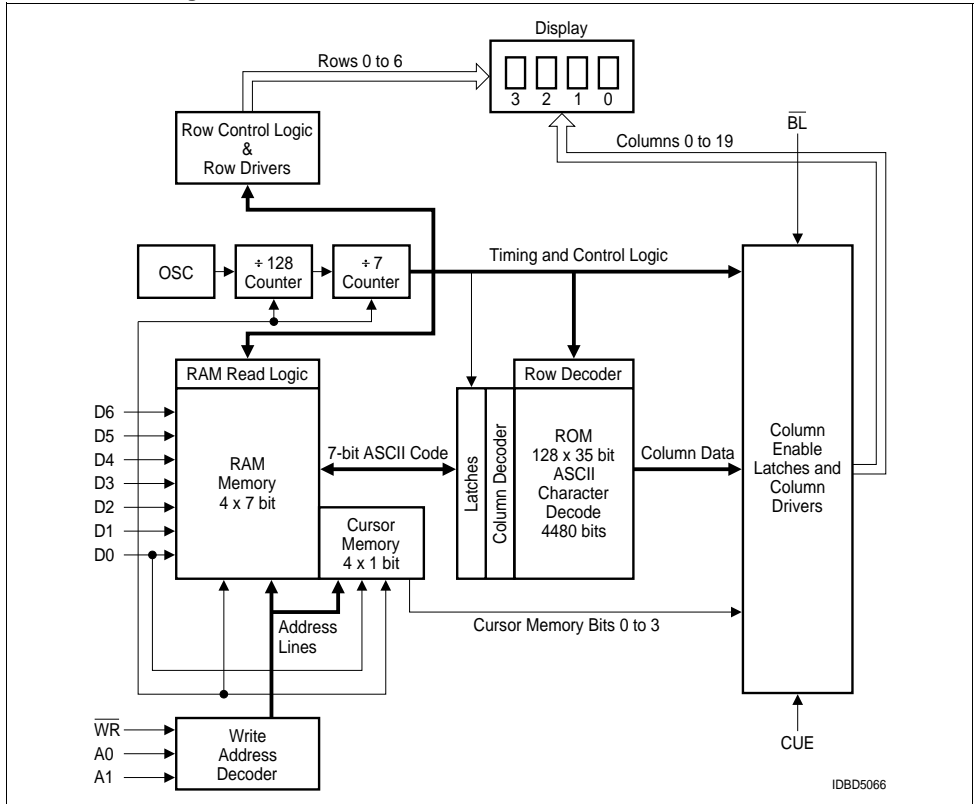

Loading Data Table

Control							Address		Data								Display Digit			
$\overline{\text{BL}}$	$\overline{\text{CE1}}$	$\overline{\text{CE2}}$	CUE	$\overline{\text{CU}}$	$\overline{\text{WR}}$	$\overline{\text{CLR}}$	A1	A0	D6	D5	D4	D3	D2	D1	D0	3	2	1	0	
H	X	X	L	X	H	H	previously loaded display								G	R	E	Y		
H	H	X	L	X	X	H	X	X	X	X	X	X	X	X	X	G	R	E	Y	
H	X	H	L	X	X	H	X	X	X	X	X	X	X	X	X	G	R	E	Y	
H	L	L	L	H	L	H	L	L	H	L	L	L	H	L	H	G	R	E	E	
H	L	L	L	H	L	H	L	H	H	L	H	L	H	L	H	G	R	U	E	
H	L	L	L	H	L	H	H	L	H	L	L	H	H	L	L	G	L	U	E	
H	L	L	L	H	L	H	H	H	H	L	L	L	L	H	L	B	L	U	E	
L	X	X	X	X	H	H	X	X	blank display											
H	L	L	L	H	L	H	H	H	H	L	L	L	H	H	H	G	L	U	E	
H	X	X	L	X	H	L	X	X	clears character displays											
H	L	L	L	H	L	H	X	X	see character code								see character set			

X=don't care

Loading Cursor Table

																	Digit				
$\overline{\text{BL}}$	CE1	CE2	$\overline{\text{CE3}}$	$\overline{\text{CE4}}$	CUE	$\overline{\text{CU}}$	$\overline{\text{WR}}$	$\overline{\text{CLR}}$	A1	A0	D6	D5	D4	D3	D2	D1	D0	3	2	1	0
H	X	X	X	X	L	X	H	H	previously loaded display								B	E	A	R	
H	X	X	X	X	H	X	H	H	display previously stored cursors								B	E	A	R	
H	H	H	L	L	H	L	L	H	L	L	X	X	X	X	X	X	H	B	E	A	n
H	H	H	L	L	H	L	L	H	L	H	X	X	X	X	X	X	H	B	E	n	n
H	H	H	L	L	H	L	L	H	H	L	X	X	X	X	X	X	H	B	n	n	n
H	H	H	L	L	H	L	L	H	H	H	X	X	X	X	X	X	H	n	n	n	n
H	H	H	L	L	H	L	L	H	H	L	X	X	X	X	X	X	L	n	E	n	n
H	X	X	X	X	L	X	H	H	disable cursor display								B	E	A	R	
H	H	H	L	L	L	L	L	H	H	H	X	X	X	X	X	X	L	B	E	A	R
H	X	X	X	X	H	H	X	H	display stored cursors								B	E	n	n	

X=don't care n= all dots on

Loading Data

Setting the chip enable ($\overline{CE1}$, $\overline{CE2}$) to their true state will enable data loading. The desired data code (D0-D6) and digit address (A0, A1) must be held stable during the write cycle for storing new data.

Data entry may be asynchronous and random. Digit 0 is defined as right hand digit with $A1=A2=0$.

To clear the entire internal four-digit memory hold the clear (\overline{CLR}) low for 1.0 μ s. All illuminated dots will be turned off within one complete display multiplex cycle, 1.0 ms minimum. The clear function will clear both the ASCII RAM and the cursor RAM.

Loading Cursor

Setting the chip enables ($\overline{CE1}$, $\overline{CE2}$) and cursor select (\overline{CU}) to their true state will enable cursor loading. A write (\overline{WR}) pulse will now store or remove a cursor into the digit location addressed by A0, A1, as defined in data entry. A cursor will be stored if $D0=1$ and will be removed if $D0=0$. The cursor (\overline{CU}) pulse width should not be less than the write (\overline{WR}) pulse or erroneous data may appear in the display.

If the cursor is not required, the cursor enable signal (CUE) may be tied low to disable the cursor function. For a flashing cursor, simply pulse CUE. If the cursor has been loaded to any or all positions in the display, then CUE will control whether the cursor(s) or the characters will appear. CUE does not affect the contents of cursor memory.

Display Blanking

Blanking the display may be accomplished by loading a blank or space into each digit of the display or by using the (BL) display blank input.

Setting the (BL) input low does not affect the contents of either data or cursor memory.

A flashing circuit can easily be constructed using a 555 as table multivibrator. Figure 4 illustrates a circuit in which varying R2 (100K~10K) will have a flash rate of 1.0 Hz~10 Hz.

The display can be dimmed by pulse width modulating the (BL) at a frequency sufficiently fast to not interfere with the internal clock. The dimming signal frequency should be 2.5 kHz or higher. Dimming the display also reduces power consumption.

An example of a simple dimming circuit using a 556 is illustrated in Figure 5. Adjusting potentiometer R3 will dim the display by changing the blanking pulse duty cycle.

Design Considerations

For details on design and applications of the DLX2416 using standard bus configurations in multiple display systems, or parallel I/O devices, such as the 8255 with an 8080 or memory mapped addressing on processors such as the 8080, Z80, 6502, or 6800, refer to Apnote 14 at www.osram-os.com.

DLX2416—Flashing Circuit Using a 555 and Flashing (Blanking) Timing

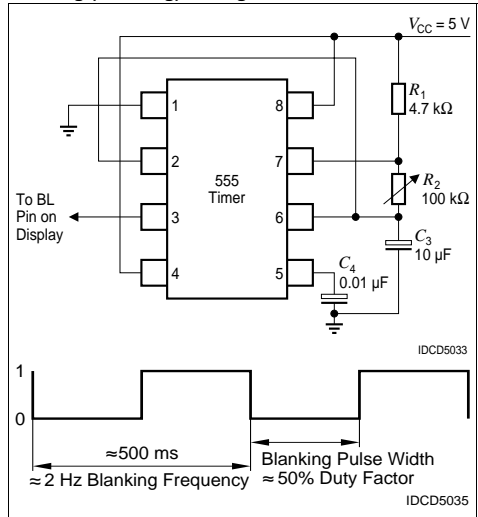

DLX2416—Dimming Circuit Using a 556 and Dimming (Blanking) Timing

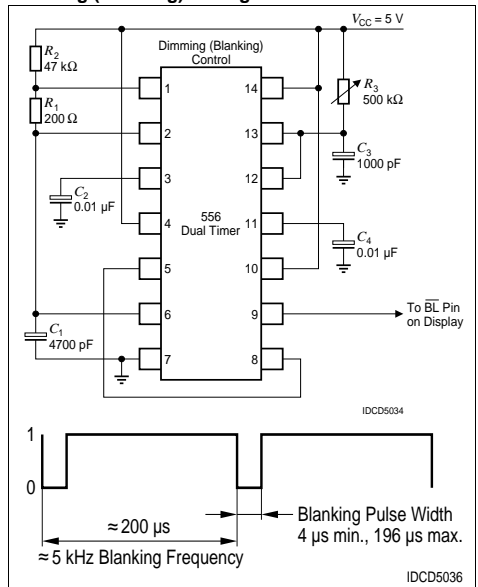

Electrical and Mechanical Considerations**Voltage Transient Suppression**

We recommend that the same power supply be used for the display and the components that interface with the display to avoid logic inputs higher than V_{CC} . Additionally, the LEDs may cause transients in the power supply line while they change display states. The common practice is to place .01 mF capacitors close to the displays across V_{CC} and GND, one for each display, and one 10 mF capacitor for every second display.

ESD Protection

The silicon gate CMOS IC of the DLX2416 is quite resistant to ESD damage and capable of withstanding discharges greater than 2.0 kV. However, take all the standard precautions, normal for CMOS components. These include properly grounding personnel, tools, tables, and transport carriers that come in contact with unshielded parts. If these conditions are not, or cannot be met, keep the leads of the device shorted together or the parts in anti-static packaging.

Soldering Considerations

The DLX2416 can be hand soldered with SN63 solder using a grounded iron set to 260°C.

Wave soldering is also possible following these conditions: Pre-heat that does not exceed 93°C on the solder side of the PC board or a package surface temperature of 85°C. Water soluble organic acid flux (except carboxylic acid) or rosin-based RMA flux without alcohol can be used.

Wave temperature of 245°C \pm 5°C with a dwell between 1.5 sec. to 3.0 sec. Exposure to the wave should not exceed temperatures above 260°C for five seconds at 0.063" below the seating plane. The packages should not be immersed in the wave.

Post Solder Cleaning Procedures

The least offensive cleaning solution is hot D.I. water (60°C) for less than 15 minutes. Addition of mild saponifiers is acceptable. Do not use commercial dishwasher detergents.

For faster cleaning, solvents may be used. Carefully select any solvent as some may chemically attack the nylon package. Maximum exposure should not exceed two minutes at elevated temperatures. Acceptable solvents are TF (trichlorofluoroethane), TA, 111 Trichloroethane, and unheated acetone.

Note:

Acceptable commercial solvents are: Basic TF, Arklone, P, Genesolv, D, Genesolv DA, Blaco-Tron TF and Blaco-Tron TA. Unacceptable solvents contain alcohol, methanol, methylene chloride, ethanol, TP35, TCM, TMC, TMS+, TE, or TES. Since many commercial mixtures exist, contact a solvent vendor for chemical composition information. Some major solvent manufacturers are: Allied Chemical Corporation, Specialty Chemical Division, Morristown, NJ; Baron-Blakeslee, Chicago, IL; Dow Chemical, Midland, MI; E.I. DuPont de Nemours & Co., Wilmington, DE.

For further information refer to Appnotes 18 and 19 at www.osram-os.com.

An alternative to soldering and cleaning the display modules is to use sockets. Standard pin DIP sockets .600" wide with 0.100" centers work well for single displays. Multiple display assemblies are best handled by longer SIP sockets or DIP sockets when available for uniform package alignment. Socket manufacturers are Aries Electronics, Inc., Frenchtown, NJ; Garry Manufacturing, New Brunswick, NJ; Robinson-Nugent, New Albany, IN; and Samtec Electronic Hardware, New Albany, IN.

For further information refer to Appnote 22 at www.osram-os.com.

Optical Considerations

The 0.200" high characters of the DLX2416 gives readability up to eight feet. Proper filter selection enhances readability over this distance.

Filters enhance the contrast ratio between a lit LED and the character background intensifying the discrimination of different characters. The only limitation is cost. Take into consideration the ambient lighting environment for the best cost/benefit ratio for filters.

Incandescent (with almost no green) or fluorescent (with almost no red) lights do not have the flat spectral response of sunlight. Plastic band-pass filters are an inexpensive and effective way to strengthen contrast ratios.

The DLR2416 is a standard red display and should be matched with long wavelength pass filter in the 600 nm to 620 nm range. The DLO2416 is a high efficiency red display and should be matched with a long wavelength pass filter in the 470 nm to 590 nm range. The DLG2416 should be matched with a yellow-green band-pass filter that peaks at 565 nm. For displays of multiple colors, neutral density gray filters offer the best compromise.

Additional contrast enhancement is gained by shading the displays. Plastic band-pass filters with built-in louvers offer the next step up in contrast improvement. Plastic filters can be improved further with anti-reflective coatings to reduce glare. The trade-off is fuzzy characters. Mounting the filters close to the display reduces this effect. Take care not to overheat the plastic filter by allowing for proper air flow.

Optimal filter enhancements are gained by using circular polarized, anti-reflective, band-pass filters. Circular polarizing further enhances contrast by reducing the light that travels through the filter and reflects back off the display to less than 1%.

Several filter manufacturers supply quality filter materials. Some of them are: Panelgraphic Corporation, W. Caldwell, NJ; SGL Homa-lite, Wilmington, DE; 3M Company, Visual Products Division, St. Paul, MN; Polaroid Corporation, Polarizer Division, Cambridge, MA; Marks Polarized Corporation, Deer Park, NY, Hoya Optics, Inc., Fremont, CA.

One last note on mounting filters: recessing displays and bezel assemblies is an inexpensive way to provide a shading effect in overhead lighting situations. Several Bezel manufacturers are: R.M.F. Products, Batavia, IL; Nobex Components, Griffith Plastic Corp., Burlingame, CA; Photo Chemical Products of California, Santa Monica, CA; .E.E.-Atlas, Van Nuys, CA.

Refer to Appnote 23 at www.osram-os.com.

Published by
OSRAM Opto Semiconductors GmbH
Wernerwerkstrasse 2, D-93049 Regensburg
www.osram-os.com
© All Rights Reserved.